

HC 高负荷荷重形 HCW-CB /HCW-HB

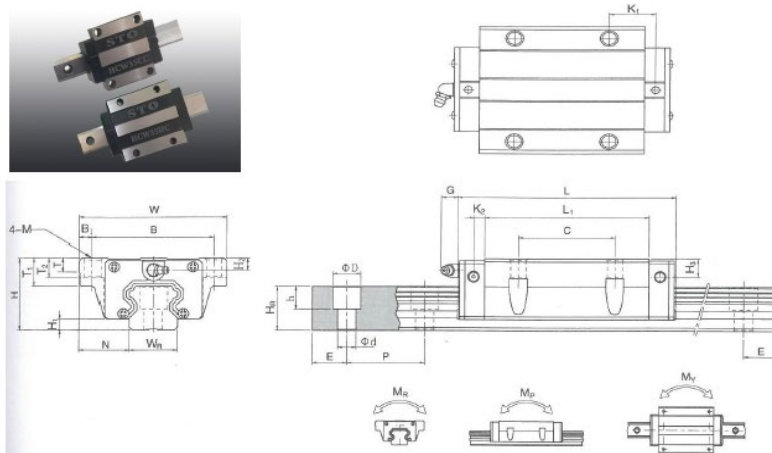

轴承型号 Bearing NO.	主要尺寸 (mm) Dimentions				滑块尺寸 (mm) Block Dimentions														导轨尺寸 (mm) Rail Dimentions							重量 Weight	
	H	H1	N	W	B	B1	C	L1	L	K1	K2	G	M	T	T1	T2	H2	H3	WR	HR	D	h	d	P	E	kg	kg/m
HCW 15CB	24	4.3	16.0	47.0	38.0	4.5	30.0	39.4	61.4	8.0	4.85	5.3	Φ5	6.0	8.9	6.95	3.95	3.7	15.0	15.0	7.5	5.3	4.5	60.0	20.0	0.17	1.45
HCW 20CB	30	4.6	21.5	63.0	53.0	5.0	40.0	50.5	77.5	10.25	6.0	12.0	Φ6	8.0	10.0	9.5	6.0	6.0	20.0	17.5	9.5	8.5	6.0	60.0	20.0	0.40	2.21
HCW 20HB								65.2	92.2	17.6																0.52	0.52
HCW 25CB	36	5.5	23.5	70.0	57.0	6.5	45.0	58.0	84.0	10.7	6.0	12.0	Φ8	8.0	14.0	10.0	6.0	5.0	23.0	22.0	11.0	9.0	7.0	60.0	20.0	0.59	3.21
HCW 25HB								78.6	104.6	21.0																0.80	0.80
HCW 30CB	42	6.0	31.0	90.0	72.0	9.0	52.0	70.0	97.4	14.25	6.0	12.0	Φ10	8.5	16.0	10.0	6.5	10.8	28.0	26.0	14.0	12.0	9.0	80.0	20.0	1.09	4.47
HCW 30HB								93.0	120.4	25.75																1.44	1.44
HCW 35CB	48	7.5	33.0	100.0	82.0	9.0	62.0	80.0	112.4	14.6	7.0	12.0	Φ10	10.1	18.0	13.0	9.0	12.6	34.0	29.0	14.0	12.0	9.0	80.0	20.0	1.56	6.30
HCW 35HB								105.8	138.2	27.5																2.06	2.06
HCW 45CB	60	9.5	37.5	120.0	100.0	10.0	80.0	97.0	139.4	13.0	10.0	12.9	Φ12	15.1	22.0	15.0	8.5	20.5	45.0	38.0	20.0	17.0	14.0	105.0	22.5	2.79	10.41
HCW 45HB								128.8	171.2	28.9																3.69	3.69
HCW 55CB	70	13.0	43.5	140.0	116.0	12.0	95.0	117.7	166.7	17.35	11.0	12.9	Φ14	17.5	26.5	17.0	12.0	19.0	53.0	44.0	23.0	20.0	16.0	120.0	30.0	4.52	15.08
HCW 55HB								155.8	204.8	36.4																5.96	5.96
HCW 65CB	90	15.0	53.5	170.0	142.0	14.0	110.0	144.2	200.0	23.1	14.0	12.9	Φ16	25.0	37.5	23.0	15.0	15.0	63.0	53.0	26.0	22.0	18.0	150.0	35.0	9.17	21.18
HCW 65HB								203.6	259.6	52.8																12.89	12.89

注: 1kgh=9.81N