

HC 高负荷荷重形
HCW-CA /HCW-HA

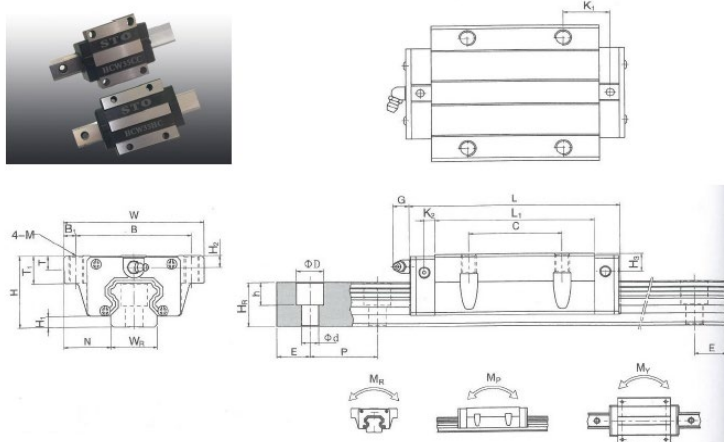

轴承型号 Bearing NO.	主要尺寸 (mm) Dimentions				滑块尺寸 (mm) Block Dimentions													导轨尺寸 (mm) Rail Dimentions						重量 Weight		
	H	H1	N	W	B	B1	C	L1	L	K1	K2	G	M	T	T1	H2	H3	WR	HR	D	h	d	P	E	kg	kg/m
HCW 15CA HCW 15HA	24	4.3	16.0	47.0	38.0	4.5	30.0	39.4	61.4	8.0	4.85	5.3	M5	6.0	8.9	3.95	3.7	15.0	15.0	7.5	5.3	4.5	60.0	20.0	0.17	1.45
HCW 20CA HCW 20HA	30	4.6	21.5	63.0	53.0	5.0	40.0	50.5 65.2	77.5 92.2	10.25 17.6	6.0	12.0	M6	8.0	10.0	6.0	6.0	20.0	17.5	9.5	8.5	6.0	60.0	20.0	0.40 0.52	2.21
HCW 25CA HCW 25HA	36	5.5	23.5	70.0	57.0	6.5	45.0	58.0 78.6	84.0 104.6	10.7 21.0	6.0	12.0	M8	8.0	14.0	6.0	5.0	23.0	22.0	11.0	9.0	7.0	60.0	20.0	0.59 0.80	3.21
HCW 30CA HCW 30HA	42	6.0	31.0	90.0	72.0	9.0	52.0	70.0 93.0	97.4 120.4	14.25 25.75	6.0	12.0	M10	8.5	16.0	6.5	10.8	28.0	26.0	14.0	12.0	9.0	80.0	20.0	1.09 1.44	4.47
HCW 35CA HCW 35HA	48	7.5	33.0	100.0	82.0	9.0	62.0	80.0 105.8	112.4 138.2	14.6 27.5	7.0	12.0	M10	10.1	18.0	9.0	12.6	34.0	29.0	14.0	12.0	9.0	80.0	20.0	1.56 2.06	6.30
HCW 45CA HCW 45HA	60	9.5	37.5	120.0	100.0	10.0	80.0	97.0 128.8	139.4 171.2	13.0 28.9	10.0	12.9	M12	15.1	22.0	8.5	20.5	45.0	38.0	20.0	17.0	14.0	105.0	22.5	2.79 3.69	10.41
HCW 55CA HCW 55HA	70	13.0	43.5	140.0	116.0	12.0	95.0	117.7 155.8	166.7 204.8	17.35 36.4	11.0	12.9	M14	17.5	26.5	12.0	19.0	53.0	44.0	23.0	20.0	16.0	120.0	30.0	4.52 5.96	15.08
HCW 65CA HCW 65HA	90	15.0	53.5	170.0	142.0	14.0	110.0	144.2 203.6	200.0 259.6	23.1 52.8	14.0	12.9	M16	25.0	37.5	15.0	15.0	63.0	53.0	26.0	22.0	18.0	150.0	35.0	9.17 12.89	21.18

注: 1kgh=9.81N