

直线导轨轴承

LINEAR guide bearing

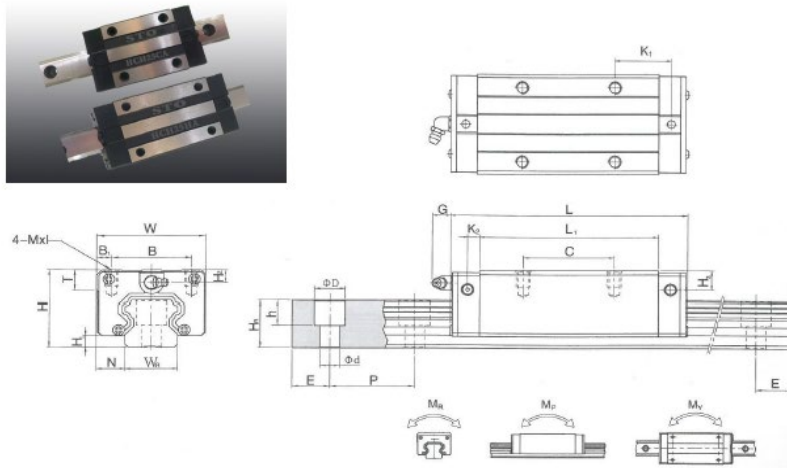

HC 高负荷荷重形 HCL-CA /HCL-HA



轴承型号 Bearing NO.	主要尺寸 (mm) Dimentions				滑块尺寸 (mm) Block Dimentions													导轨尺寸 (mm) Rail Dimentions							重量 Weight	
	H	H1	N	W	B	B1	C	L1	L	K1	K2	G	M*1	T	H2	H3	WR	HR	D	h	d	P	E	kg	kg/m	
HCL 15CA	24	4.3	9.5	34.0	26.0	4.0	26.0	39.4	61.4	10.0	4.85	5.3	M4*4	6.0	3.95	3.7	15.0	15.0	7.5	5.3	4.5	60.0	20.0	0.14	1.45	
HCL 25CA	36	5.5	12.5	48.0	35.0	6.5	35.0	58.0	84.0	15.7	6.0	12.0	M6*6	8.0	6.0	5.0	23.0	22.0	11.0	9.0	7.0	60.0	20.0	0.42	3.21	
HCL 25HA							50.5	78.6	104.6	18.5														0.57		
HCL 30CA	42	6.0	16.0	60.0	40.0	10.0	40.0	70.0	97.4	20.25	6.0	12.0	M8*10	8.5	6.5	10.8	28.0	26.0	14.0	12.0	9.0	80.0	20.0	0.78	4.47	
HCL 30HA							60.0	93.0	120.4	21.75														1.03		
HCL 35CA	48	7.5	18.0	70.0	50.0	10.0	50.0	80.0	112.4	20.6	7.0	12.0	M8*12	10.2	9.0	12.6	34.0	29.0	14.0	12.0	9.0	80.0	20.0	1.14	6.30	
HCL 35HA							72.0	105.8	138.2	22.5														1.52		
HCL 45CA	60	9.5	20.5	86.0	60.0	13.0	60.0	97.0	139.4	23.0	10.0	12.9	M10*17	16.0	8.5	20.5	45.0	38.0	20.0	17.0	14.0	105.0	22.5	2.08	10.41	
HCL 45HA							80.0	128.8	171.2	28.9														2.75		
HCL 55CA	70	13.0	23.5	100.0	75.0	12.5	75.0	117.7	166.7	27.35	11	12.9	M12*18	17.5	12.0	19.0	53.0	44.0	23.0	20.0	16.0	120.0	30.0	3.25	15.08	
HCL 55HA							95.0	155.8	204.8	36.4														4.27		

注: 1kgh=9.81N