

# 直线导轨轴承

LINEAR guide bearing

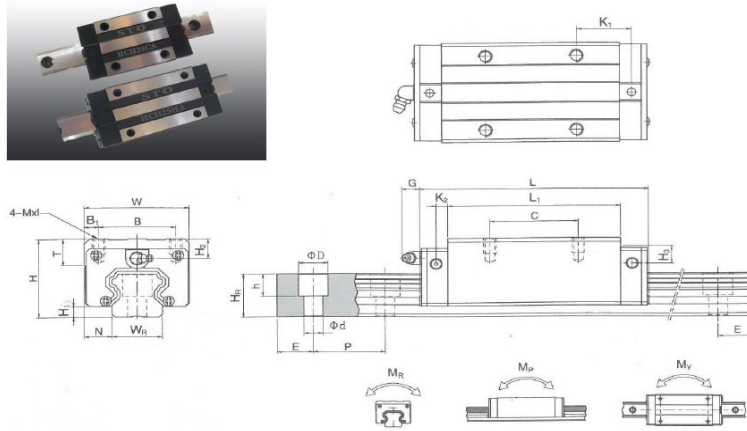

## HC 高负荷荷重形 HCH-CA / HCH-HA



轴承型号 Bearing NO.	主要尺寸 (mm) Dimentions				滑块尺寸 (mm) Block Dimentions													导轨尺寸 (mm) Rail Dimentions							重量 Weight	
	H	H1	N	W	B	B1	C	L1	L	K1	K2	G	M*1	T	H2	H3	WR	HR	D	h	d	P	E	kg	kg/m	
HCH 15CA	28	4.3	9.5	34.0	26.0	4.0	26.0	39.4	61.4	10.0	4.85	5.3	M4*5	6.0	7.95	7.7	15.0	15.0	7.5	5.3	4.5	60.0	20.0	0.18	1.45	
HCH 20CA	30	4.6	12.0	44.0	32.0	6.0	36.0	50.5	77.5	12.25	6.0	12.0	M5*6	8.0	6.0	7.0	20.0	17.5	9.5	8.5	6.0	60.0	20.0	0.30	2.21	
HCH 20HA							50.0	65.2	92.2	12.6														0.39		
HCH 25CA	40	5.5	12.5	48.0	35.0	6.5	35.0	58.0	84.0	16.8	6.0	12.0	M6*8	8.0	10.0	13.0	23.0	22.0	11.0	9.0	7.0	60.0	20.0	0.51	3.21	
HCH 25HA							50.0	78.6	104.6	19.6														0.69		
HCH 30CA	45	6.0	16.0	60.0	40.0	10.0	40.0	70.0	97.4	20.25	6.0	12.0	M8*10	8.5	9.5	13.8	28.0	26.0	14.0	12.0	9.0	80.0	20.0	0.88	4.47	
HCH 30HA							60.0	93.0	120.4	21.75														1.16		
HCH 35CA	55	7.5	18.0	70.0	50.0	10.0	50.0	80.0	112.4	20.6	7.0	12.0	M8*12	10.2	16.0	19.6	34.0	29.0	14.0	12.0	9.0	80.0	20.0	1.45	6.30	
HCH 35HA							72.0	105.8	138.2	22.5														1.92		
HCH 45CA	70	9.5	20.5	86.0	60.0	13.0	60.0	97	139.4	23.0	10.0	12.9	M10*17	16.0	18.5	30.5	45.0	38.0	20.0	17.0	14.0	105.0	22.5	2.73	10.41	
HCH 45HA							80.0	128.8	171.2	28.9														3.61		
HCH 55CA	80	13.0	23.5	100.0	75.0	12.5	75.0	117.7	166.7	27.35	11.0	12.9	M12*18	17.5	22.0	29.0	53.0	44.0	23.0	20.0	16.0	120.0	30.0	4.17	15.08	
HCH 55HA							95.0	155.8	204.8	36.4														5.49		
HCH 65CA	90	15.0	31.5	126.0	76.0	25.0	70.0	144.2	200.2	43.1	14.0	12.9	M16*20	25.0	15.0	15.0	63.0	53.0	26.0	22.0	18.0	150.0	35.0	7.00	21.18	
HCH 65HA							120.0	203.6	203.6	47.8														9.82		