

直线导轨轴承

LINEAR guide bearing

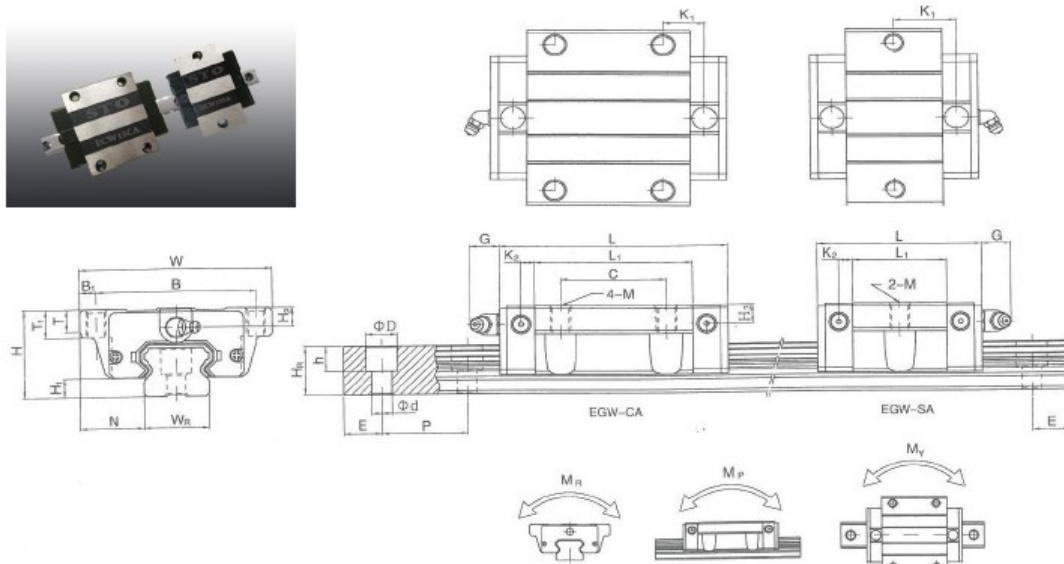

EC 低紧凑型 ECW-SA / ECW-CA



轴承型号 Bearing NO.	主要尺寸 (mm) Dimentions				滑块尺寸 (mm) Block Dimentions													导轨尺寸 (mm) Rail Dimentions						重量 Weight		
	H	H1	N	W	B	B1	C	L1	L	K1	K2	G	M*1	T	T1	H2	H3	WR	HR	D	h	d	P	E	kg	kg/m
ECW 15SA	24	4.5	18.5	52.0	41.0	5.5	-	23.1	40.1	14.8	3.5	5.7	Φ4.5	5.0	7.0	5.5	6.0	15.0	12.5	6.0	4.5	3.5	60.0	20.0	0.12	1.25
ECW 15CA							26.0	39.8	56.8	10.15															0.21	
ECW 20SA	28	6.0	19.5	59.0	49.0	5.0	-	29	50.0	18.75	4.15	12.0	Φ5.5	7.0	9.0	6.0	6.0	20.0	15.5	9.5	8.5	6.0	60.0	20.0	0.19	2.08
ECW 20CA							32.0	48.1	69.1	12.3															0.32	
ECW 25SA	33	7.0	25.0	73.0	60.0	6.5	-	35.5	59.1	21.9	4.55	12.0	Φ7.0	7.5	10.0	8.0	8.0	23.0	18.0	11.0	9.0	7.0	60.0	20.0	0.35	2.67
ECW 25CA							35.0	59.0	82.6	16.15															0.59	
ECW 30SA	42	10.0	31.0	90.0	72.0	9.0	-	41.5	69.5	26.75	6.0	12.0	Φ9.0	7.0	10.0	8.0	9.0	28.0	23.0	11.0	9.0	7.0	80.0	20.0	0.62	4.35
ECW 30CA							40.0	70.1	98.1	21.05															1.04	
ECW 35SA	48	11.0	33.0	100.0	82.0	9.0	-	45.0	75.0	28.5	7.0	12.0	Φ9.0	10.0	13.0	8.5	8.5	34.0	27.5	14.0	12.0	9.0	80.0	20.0	0.84	6.14
ECW 35CA							50.0	78.0	108.0	20.0															1.45	

注: 1kgh=9.81N